



# **Guidelines for assembling and maintenance**



## **Smoke extraction ducts**

## Guidelines for assembling and maintenance for the SMOKEDUKE ducts

### General

The smoke extraction ducts will prevent the spreading of the smoke and burnt material from the area of fire. The smoke extraction ducts are part of the smoke and fire prevention system, which should be designed by professionals. [1]

The system is part of the smoke and fire protection system and is intended to achieve the following objectives:

- Remove the smoke for 2 hours during a fire
- Reduced temperature during fire
- Creating a smokeless level
- Protecting property

These Guidelines applies to a single-compartment smoke control system constructed of rectangular ducts, tested for two hours at 600°C, +500 Pa overpressure, and -1500 Pa vacuum in horizontal position.

Test method: EN 1366-9 Fire resistance test, one-compartment smoke control channels  
Requirements: EN 12101-7 Smoke control systems, smoke control channels

The mentioned test fulfills the European Standard EN 12101-7 and entitles us to use CE mark on our ventilation ducts.

The **SmokeDuke** ducts are manufactured from galvanized (275g/m<sup>2</sup>) metal sheets, thickness 1,0 mm. The maximum size of the duct is 1250 x 1000 mm, and the maximum length of duct is 2000 mm. The Europrofile (DW30) system is used to combine ducts and parts together.

To fulfill the standard EN 12101-7, all the parts as well as the installation of the duct system should have done according to the standard.

### The installation

The duct parts are covered during delivery. Delivery must be checked and accepted upon receipt. Visual defects and faults must be reported immediately. The responsibility for the products transfers to the customer upon receipt. The duct parts need to be covered against weather and other damaging items (including dust, dirt, moist) during the storing. Before the installation, make sure that the duct system can be assembled according to the plans. Use only the undamaged and clean parts. The installation should be carried out according to the manufacturers' guidelines. Guidelines are also available at [www.pkkanavat.fi](http://www.pkkanavat.fi).

The system is certified together with supports, flanges, sealing material and compensators. All components must be used in the same way as in the test. Any component of the system cannot be replaced by others. The system is CE marked and has a Declaration of Performance for a rectangular one-compartment smoke management system.

### Compensator

In horizontal and vertical installations, observe the need for a compensator in a duct system of more than five meters and a compensator for each of the nine meters ahead. The compensator reduces the stresses to solid structures. Compensator manufacturer instructions must be followed when installing the compensator, and we provide the manufacturer's instructions as an attachment.

## CE-marking



Each of our smoke extraction duct carries a CE-sticker. The manufacturing date is placed on XX.XX.XXXX and the YYYYYY stands for order number.

## Air tightness between products

The joints between ducts are condensed with Tytan B1 fire mass. Please note that the surface of the flange is clean and dry before the filling. Apply the "worm of mass" to the flange of the Europrofile to the entire length. Press the duct ends together and tightens the corners together with bolt and nut. Press the duct sides together, add clamps and tighten the bolt of joint clamp. Clamps should be used every 200 mm distance or at least one on each side, to reach the air tightness.

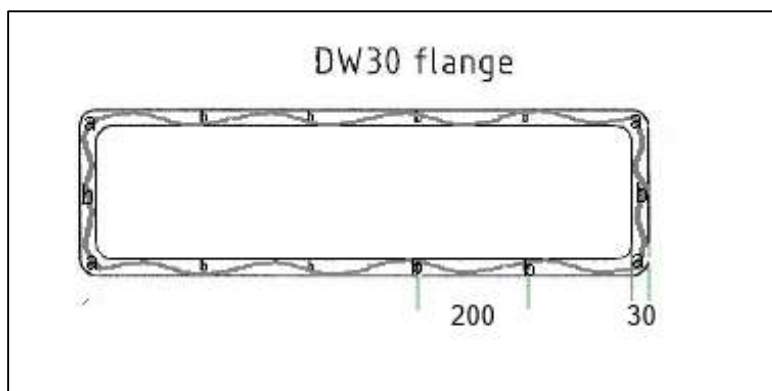

Figure 1. Sealing the joints with fire mass.

## Installation steps:

1. Apply Tytan B1 fire mass to the flange, paying special attention to the corners. The mass is applied only to another channel flange to be connected.
2. Connect the channels. Fit the corner bolts to the hand tight and then add the clamp bolts with screws. The clamps must be at least one for each channel side and not more than 200 mm apart.
3. Tighten all the screws to the required tightness to ensure the duct air tightness.

The duct supports should be able to carry ducts as well as additional external loads caused by maintenance, repair or construction work.

**Horizontal duct supporting**

For horizontal support hangers, we recommend using threaded rods (grade 8.8, M8), U-profile, washers and nuts. The support hangers must not be more than 500 mm from the channel junction point and there must be only one channel junction between the two hanger points. In horizontal installations, observe the need for a compensator in a duct system of more than five meters and a compensator for each of the nine meters ahead.

The compensator is installed fully extensible. The channels between which the compensator is to be installed must be straightened. Axial alignment error prevents system length changes in a fire situation.

Additional instructions in the HVAC card [LVI 12-10370].

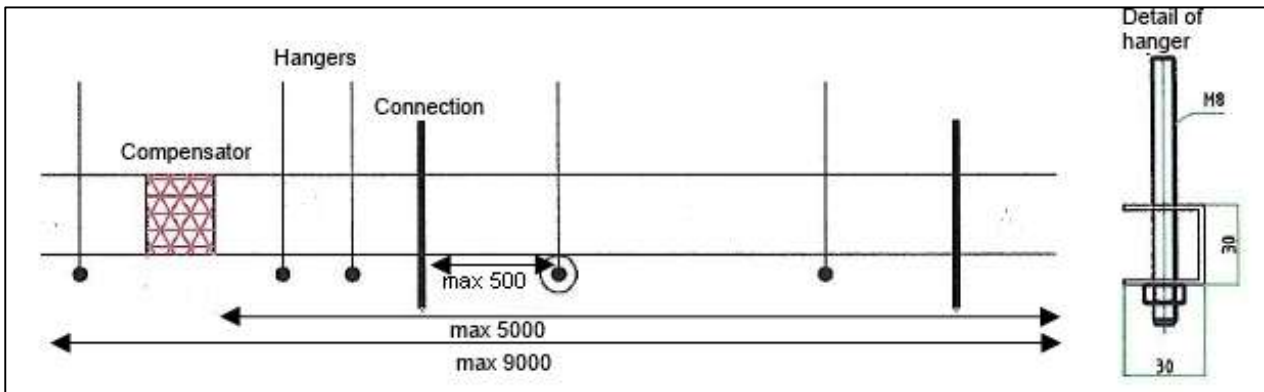
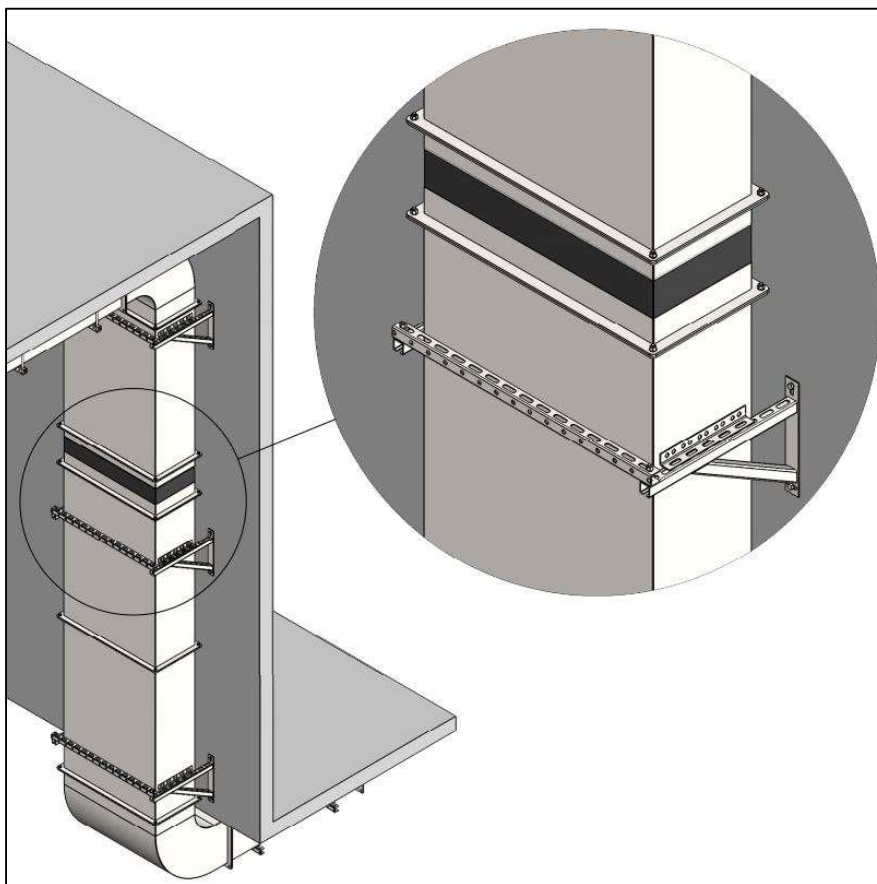

Figure 2. Horizontal smoke extraction duct support.



*Figure 3. Supporting.*

In vertical smoke extraction duct maximum distance between two wall mounted supports can be 1500 mm (see Figure 3).

In every duct support point, there must be following parts:

- Two wall supports and one C- or U-mounting rail.
- Two M8 bolts and nuts and four washers. Minimum length of the bolt is 45mm.
- Two L-mounting rails. Length of L-mounting rail is 40mm shorter than duct size. L-mounting rail is attached to the duct with blind rivets or self-drilling screws every ten cents. L-mounting rails are not attached to the wall supports at all; they just lie on top of the mounting rails.

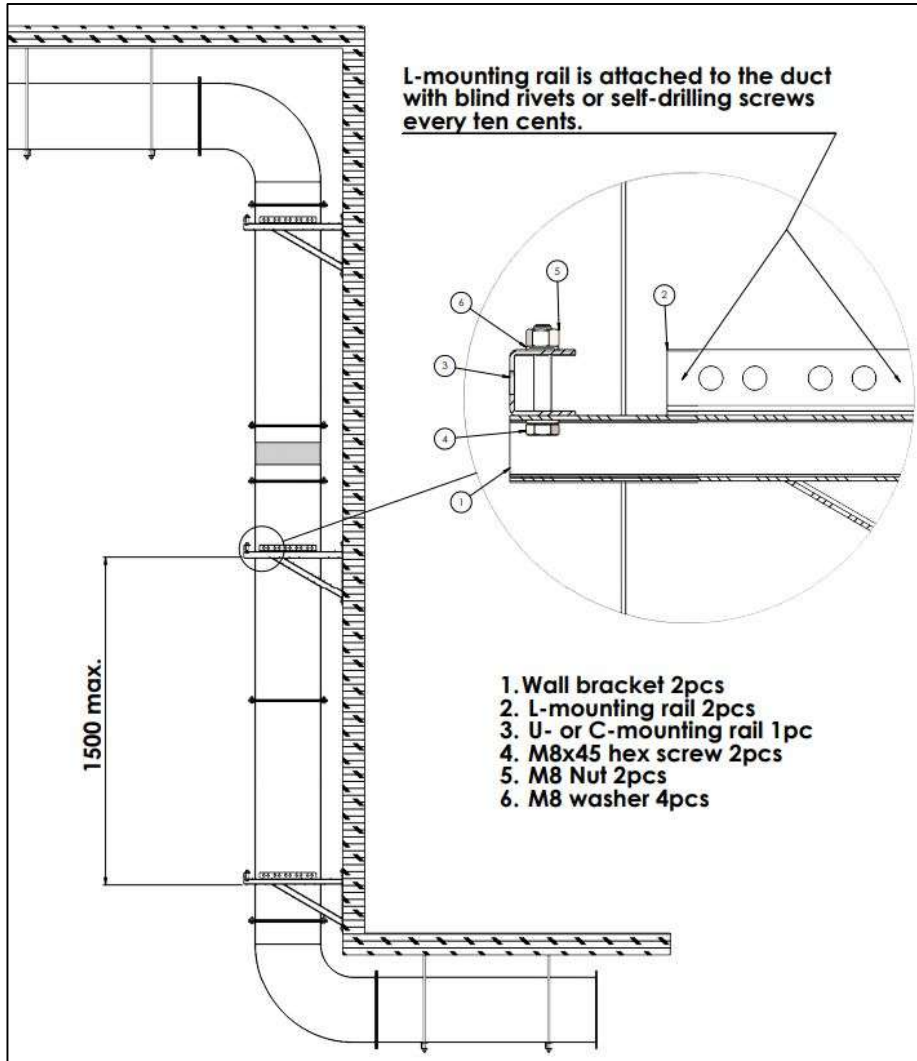

Figure 4. Vertical smoke extraction duct support.

The maintenance needs to be carried out at least every year. During the annual inspection, attention should be paid to the system components and to the connections tightness. The weight of the system must be evenly distributed on the brackets and there must be no flammable parts in the immediate vicinity of the system. If deficiencies are detected, they should be corrected. The following features need to be checked and recorded at least once a year to maintain the standardization status. The report should contain the following [1]:



Inspected feature	Result / checking date and inspector
The duct system	
The inspection date	
Damages of the duct system	
Joints between the parts (between ducts and between parts)	
Inlets between the compartments	
Cleanliness and made cleaning procedures	
Condition of the seals and possible problems and reporting of them	
Checking that the duct system work as a part of smoke extraction system	
NOTE. The smoke extraction duct is, in principle, part of the smoke management system. For this reason, the entire system should be checked in accordance with the system's operation and service requirements.	

#### Sources

1. Suomen Standardoimisliitto SFS. Standardi SFS-EN 12101-7.

## CE marking

The CE marking must comply with Directive 93/68 / EC and must be on each label in the smoke control channel and in the commercial documents supplied [SFS-EN 12101-7].

 26 NB: 1391
PK KANAVAT OY, Vanha Mikkeliintie 24 A, 76100 Pieksämäki, Finland DoP SMOKE DUKE 2
EN 12101-7 Smoke Extraction Duct  Intended use: Single compartment smoke extraction ducts, intended to use at either 600°C or in a fire situation.
<b>Mounting direction</b> h <sub>o</sub> -v <sub>e</sub>
<b>Classification</b> E <sub>600</sub> 120 h <sub>o</sub> S 1500single
Other information : <a href="http://www.pkkanavat.fi">www.pkkanavat.fi</a> Manufacture date:



**Declaration of Performance**  
DoP number: SMOKEDUKE 3

1. The unique identifier of the product type: SMOKEDUKE™ –smoke extraction duct  
2. Intended use: Single compartment smoke extraction ducts, intended to use at either 600°C or in a fire situation.  
3. Manufacturer: PK KANAVAT OY, Vanha Mikkeliintie 24 A, 76100 Pieksämäki, Finland, www.pkkanavat.fi  
5. System of assessment and verification of constancy of performance: AVCP1  
6 a. Harmonised standard: EN 12101-7:2011  
Notified body: PAVUS, a.s., No 1391  
7. Declared Performance

Essential characteristics	Performance	Harmonised technical specification
Fire resistance	Single Compartment installations 1500 Pa – pressure level 3	<b>12101-7</b>
Integrity	E <sub>600</sub> 120	
Mounting direction	h <sub>o</sub> -v <sub>e</sub>	
Insulation	-	
Smoke leakage	E <sub>600</sub> 120 S	
Mechanical stability (under E)	Approved	
Maintenance of the cross section (under E)	Approved	

The performance of the product identified in point 1 is in conformity with the declared performance in point 7. This declaration of performance is issued, in accordance with Regulation (EU) No 305/2011, under the sole responsibility of the manufacturer identified above.

Signed for and on behalf of the manufacturer by:  
**Mikko Miettinen – CEO**



Pieksämäki 17<sup>th</sup> April 2026

(place and date of issue)

(signature)